

orion[®]
FLEX[™]
S E R I E S

RT Series Rotary Tower Stretch Wrapping Systems

FLEX
S E R I E S
RT D
DELUXE

FLEX
S E R I E S
RT A
AUTOMATIC



Flex RTA shown with optional gantry frame and fencing.

Orion's Flex RT Series offers superior flexibility and reliability in a rotary tower stretch wrapping system. With a wide range of options, configurations and speeds to choose from, there's an RT model ideal for your specific pallet wrapping application.



FLEX SERIES

RTD

Flex RT Rotary Tower Stretch Wrappers: Built for High Performance & Long Life

Orion's most recent addition to the popular Flex Series, the RTD models represent the latest in rotary tower stretch packaging technology. These systems can be loaded by pallet jack or lift truck, no ramps required. There is no weight limit as loads are wrapped while sitting directly on the floor. Because RT models rotate the film carriage around a stationary load, they are ideal for unitizing even the most difficult loads, including those that are extremely heavy, light, fragile or unstable.



Flex RTD Rotary Tower Deluxe Performance Features

- 16 RPM Variable Speed Tower
- No Maximum Load Weight Capacity
- High Performance Film Delivery Carriage
- Floor Mounted Control Panel for Flexibility
- Precision Ring Bearing Drive System
- AC/VFD Motors for Reduced Maintenance
- Structural Steel Construction for Durability
- Heavy Duty Chain & Sprocket Drive
- Tower Mounted Obstacle Sensing System



*Pictured is the RT with gantry frame and fencing **options** for enhanced wrap zone protection and/or high speed applications.*



Industrial Strength Drive & Support

Tower support and drive is supplied via a precision ring bearing driven by heavy duty chain for maximum reliability in harsh industrial conditions. Orion's RevoLogic™ provides precise wrap counting and home positioning.



Orion Insta-Thread™ Film Delivery System

Flex A and D Series machines help you reduce cost with every load you wrap. With a standard film pre-stretch rate of 260% you'll not only reduce cost by using less film, the film on the load will be stronger, so loads are securely wrapped for storage or shipping.

Film threading is fast, easy and safe thanks to simple "drop-in" film loading. Simply open the gate, drop the film tail in, and close the gate.



Graphic instructions on top of the carriage guide the operator through film threading.



Flex RTA Maximizes Efficiency by Automating Wrapping Cycle

Orion's RTA system is the fastest way to boost your end-of-line packaging efficiency by eliminating the need for operators to manually attach the film tail to the load, then cut and secure the film tail at the end of the cycle. The RTA automatically performs these functions so your operators simply place the load, pull a hanging lanyard to start the cycle, and attend to other duties. When they return, the load is securely wrapped and ready to be removed.

Flex RTA Rotary Tower Automatic Performance Features

- 16 RPM Variable Speed Tower
- Automatic Film Tail Attach/Cut/Press
- Start Cycle With Hanging Lanyard
- No Maximum Load Weight Capacity
- High Performance Film Delivery Carriage
- Floor Mounted Control Panel for Flexibility
- Precision Ring Bearing Drive System
- AC/VFD Motors for Reduced Maintenance
- Structural Steel Construction for Durability
- Heavy Duty Chain & Sprocket Drive
- Tower Mounted Obstacle Sensing System



At the end of the wrapping cycle, Orion's innovative asymmetrical film clamp grips the film web while the impulse wire cuts the film. The load seeking brush then presses the film tail to the side of the load.

State-of-the-art Control Center

From its clean and simple user interface on the outside to its sophisticated programmable logic controller and AC variable frequency drives inside, every aspect of the Flex control package has been designed for maximum reliability, flexibility and ease-of-use.

PLC Controller

- Intuitive Touch Screen Interface Panel
- Non-Proprietary Telemecanique PLC
- NEMA 12 Rated Control Box
- Separate Top & Bottom Wrap Counts
- Separate Carriage Up & Down Speeds
- Maintenance-Free AC VFD Motors
- Large E-Stop / Cycle Pause Button
- Power Lockout Disconnect Switch
- Lanyard Switch Cycle Start (RTA)
- Industrial Cycle Start Button (RTD)
- Manual Jog for Machine Functions
- Includes Floor Mounted Stand



The Flex RT Series uses a durable operator touch panel to allow for easy programming of common settings. Advanced programming functions are password protected.



RT Series Specifications

PRODUCTION SPEED

RTD: Up to 30 - 40 loads per hour
 RTA: Up to 40 - 50 loads per hour
 Based on 80" tall load, 12 revolutions

MAXIMUM LOAD SIZE

RTD: 52"W x 52"L x 80"H (74" Diagonal)
 RTA: 48"W x 48"L x 80"H (68" Diagonal)

InstaThread™ FILM DELIVERY SYSTEM

Film roll: 20" Standard, 30" Optional, 10" diameter
 Standard prestretch ratio: 260% (higher available)
 Ultra low wrap to within 1.5" of floor
 Automatic load height sensing photoeye
 Automatic film force-to-load control

SHIPPING WEIGHT

2,500+ lbs. (Varies with options)

UTILITIES

115 / 1 / 60, 20 Amp electrical service
 80 PSI @ 3 CFM compressed air (RTA only)

RT Series Options

TALL LOAD OPTION

Extension for loads up to 95" or 110" tall

LARGE LOAD OPTIONS

Extension for loads up to 58" x 58" (82" diagonal)
 Extension for loads up to 65" x 65" (92" diagonal)*
 * Includes Gantry Stand

FILM DELIVERY OPTIONS

30" InstaThread™ film carriage
 Higher or lower film stretch ratio

PERIMETER PROTECTION OPTIONS

Second leg gantry style frame
 Zone protection fencing with photoeyes

SPEED OPTIONS

22 RPM upgrade (includes gantry stand/fencing)

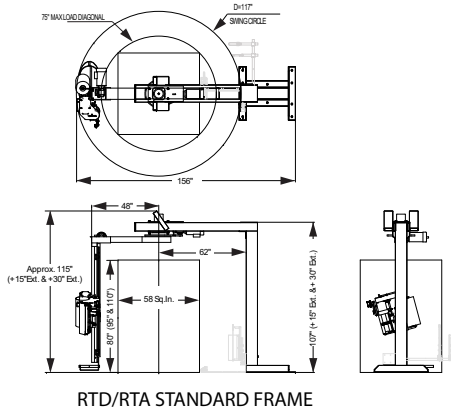

RTD/RTA STANDARD FRAME

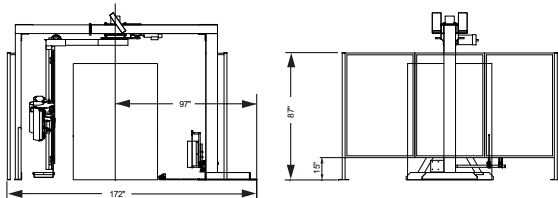
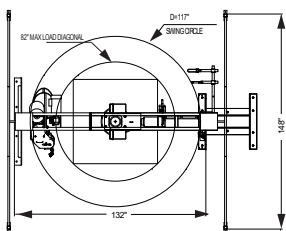

RTD/RTA WITH OPTIONAL
 GANTRY FRAME & FENCING

PPI Packaging
 Products Inc.

10 - 6581 Kitimat Road
 Mississauga, ON L5N 3T5
 Toll Free (800) 665-4040
 Telephone (905) 507-4040
 Fax (905) 285-0054
 Email: sales@ppipack.com
www.ppipack.com



Proudly Made in the U.S.A.

All dimensions approximate. Orion Packaging Systems reserves the right to change specifications without notice.

