

# HS 65-SERIES

STRAPPING MACHINE

www.ppipack.com

**NEW**

## FEATURES:

- One piece strap chute**
- Dual side control**
- Sensor controlled heater**
- Jog switch**
- Dispenser release switch**
- Auto strap ejector/ Auto strap feeding**



**The Equipment And  
Service Specialists**

# HS 65-SERIES

**STRAPPING MACHINE**

www.ppipack.com

## Easy Coil Loading



## Movable Box Control



## Features

- One Piece Strap Chute
- Dual Side Control
- Sensor Controlled Heater
- Jog Switch
- Dispenser Release Switch
- Auto Strap Ejector/ Auto Strap Feeding
- Low Voltage Control
- Single Foot Bar

## Foot Bar



## Compact Strapping Head

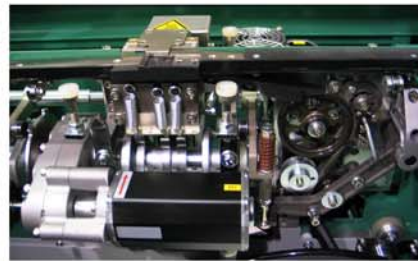

## Options

- Photo-Eye Switch
- Dual Foot Bar
- Palm Pad Switch
- Stainless Steel Frame
- Small Package Version Available

## Standard Dimensions

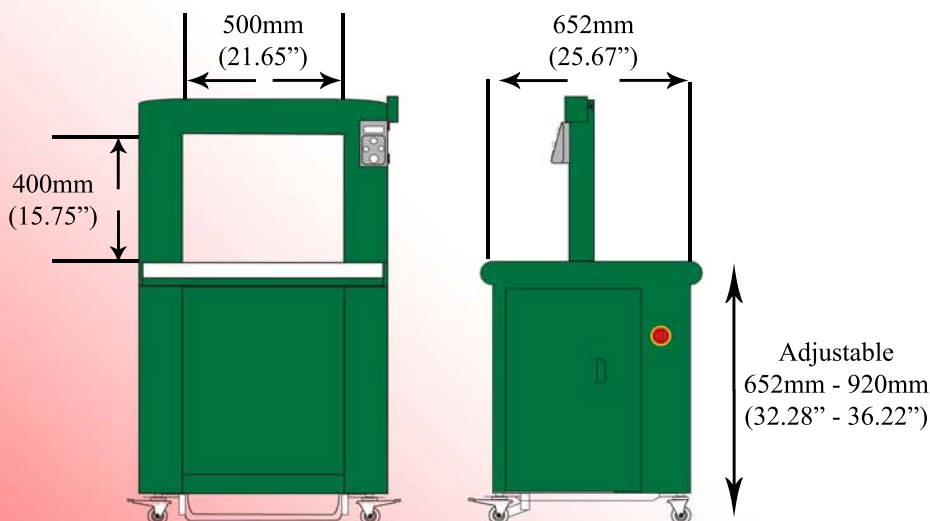

## Technical Data

- Strap Width: 5mm, 6mm, and 9mm
- Table Height: 820mm-920mm (32.28"-36.22")
- Standard Arch: 550mm H x 400mm W (21.65" H x 15.75" W) Available in other sizes
- Power Supply: 110V or sSingle Phase 60HZ